

## ILLUSTRATED PARTS LIST

FRONT DRIVE KIT  
Model No. 21124E1  
Form No. 21163E1

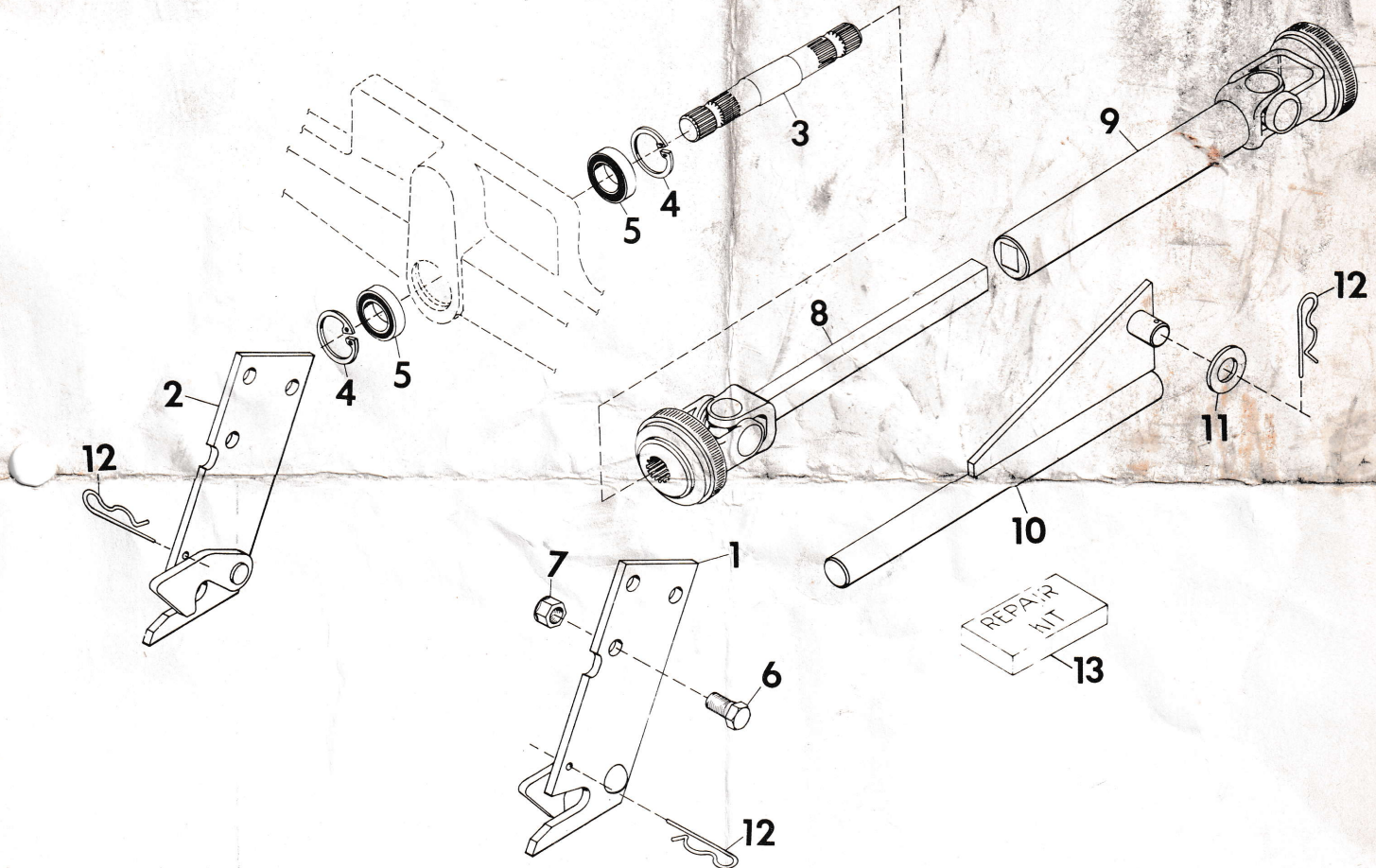

<u>LINE ITEM</u>	<u>PART NUMBER</u>	<u>DESCRIPTION</u>
1	11698A1	Bracket, Front Attachment L.H.
2	11697A1	Bracket, Front Attachment R.H.
3	18654P1	Shaft, Front P.T.O.
4	19073P1	Ring, Retaining
5	19072P1	Bearing, Ball .984 x 2.047 x .590
6	180173	Bolt, Hex 1/2-13 x 1
7	120378	Nut, Hex 1/2-13
8	19074P1	Shaft, Prop SQ. Bar
9	18653P1	Shaft, Front P.T.O. Prop
10	11396P1	Guide, Push Rod Weldment
11	131017	Washer, Flat 13/16 x 1-15/32 x .134
12	10405P1	Pin, Hair Cotter
13	12134P1	Kit, Repair Universal Joint Rockwell STD
	20573P1	Kit, Repair Universal Joint NEAPCO 1605x